

LETTO SAMBUCO DIAGO: ELEMENTI

LONGHERONE: 2 X



TRAVERSA PORTADOGHE: 2 X



TRAVERSA CENTRALE:
NEL 120 - 140 - 160: 1
NEL 170 - 180: 2

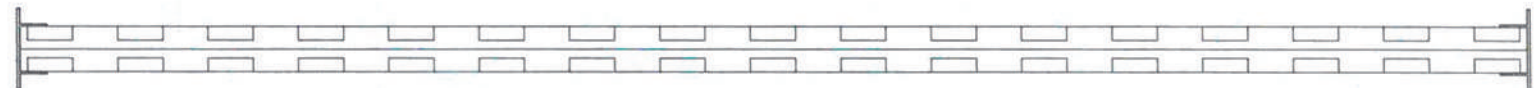

TESTATA:



DOGHE IN LEGNO
NEL 120 - 140 - 160: 30
NEL 170 - 180: 45

PEDIERA





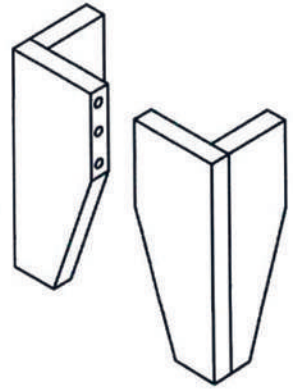

2 COPPIE PIEDI

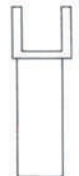

COPPIA PIEDI POSTERIORI



PIEDE CENTRALE:
NEL SINGOLO: 0
NEL 120 - 140 - 160: 1
NEL 170 - 180: 2

 8 CONFALONIERI	 52 PERNI IN LEGNO 10 X 30	 COPPIA VITI DI GIUNZIONE PER PIEDE CENTRALE: 1 PERNO MASCHIO 1 PERNO FEMMINA
 8 PERNI CONFALONIERI	 10 BULLONI 8 X 35	

ASSEMBLAGGIO COMPONENTI SAMBUCO DIAGO SINGOLO

1: INFILARE LE CONFALONIERI NEI LONGHERONI,
NELLA TESTATA E NELLA PEDIERA NEGLI
GLI APPOSITI FORI : N.B. FRECCIA RIVOLTA VERSO
L'ESTERNO - PREMERE BENE FINO IN FONDO

2: INFILARE NEI PIEDI IPERNI
PER CONFALONIERI E
I PERNI IN LEGNO 10 X 30

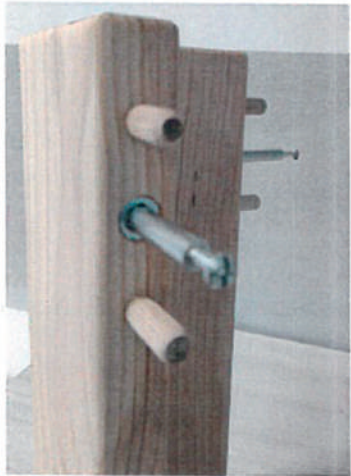

3: INSERIRE IL PIEDE CENTRALE
NELLA TRAVERSA CENTRALE
ED AVVITARLO CON LA COPPIA DI
VITI DI GIUNZIONE

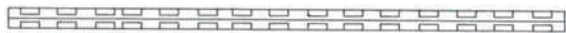

ESTERNO
OVVERO VERSO IL PIEDE

4: UNIRE TESTATA , PEDIERA
AI LONGHERONI

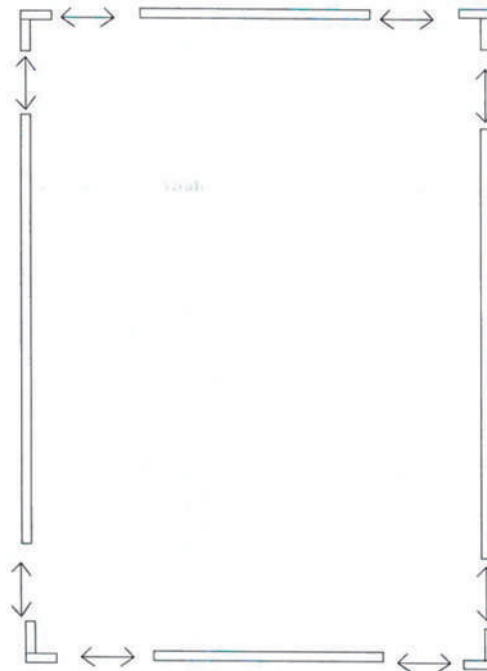

5: RUOTARE LE CONFALONIERI IN SENSO
ORARIO FINO AL SERRAGGIO
IN MODO CHE LA FRECCIA SIA RIVOLTA
VERSO L'INTERNO

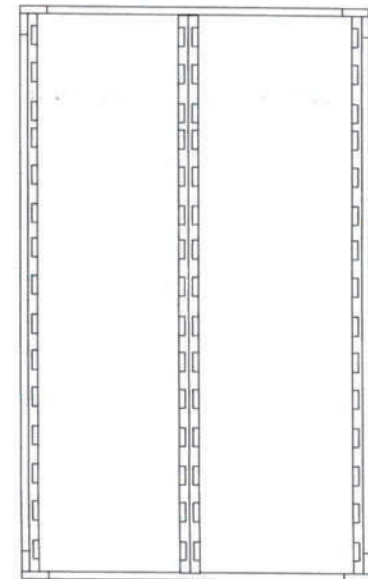

6: DOPO AVER CHIUSO LA STRUTTURA
AVVITARE I PORTADOGHE SUI LONGHERONIE PIEDI,
AVVITARE LA TRAVERSA CENTRALE .
SE NON SI HA ANCHE LA TESTATA, ALLORA
APPOGGIARE LE DOGHE NELLE APPOSITE
SEDI

TESTIERA TRE LISTE

MONTANTI:
NEL SINGOLO: 2
NEL 120 - 140 : 4
NEL 160 - 180 : 4

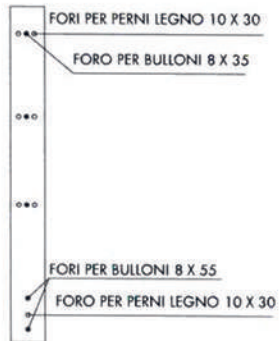

1: METTERE I PERNI LEGNO NEI FORI INFERIORI DEI MONTANTI E, SUCCESSIVAMENTE, INFILARE I MONTANTI SULLA TESTATA ED AVVITARE, NON FINO IN FONDO CON I BULLONI 8 X 55

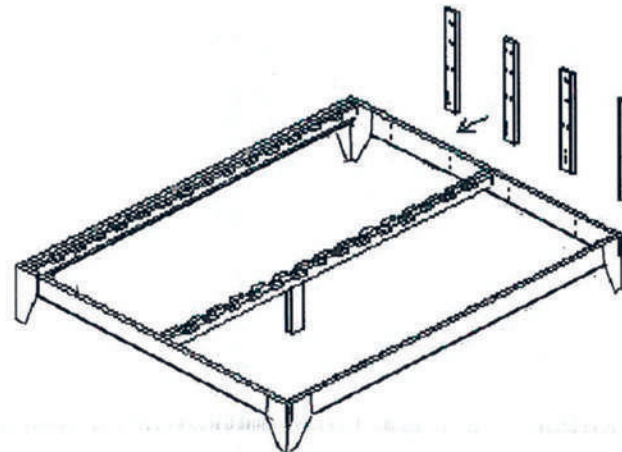

3: A QUESTO PUNTO E' POSSIBILE CHIUDERE FINO IN FONDO I BULLONI 8 X 55 E POSIZIONARE LE DOGHE NELLE APPOSITE SEDI

LISTA PER SINGOLO: 3 X



2: METTERE I PERNI LEGNO NEI FORI DEI MONTANTI E, SUCCESSIVAMENTE, INFILARE LE LISTE ED AVVITARLE CON I BULLONI 8 X 35

LISTA PER 120 - 140 - 160 - 180: 3 X

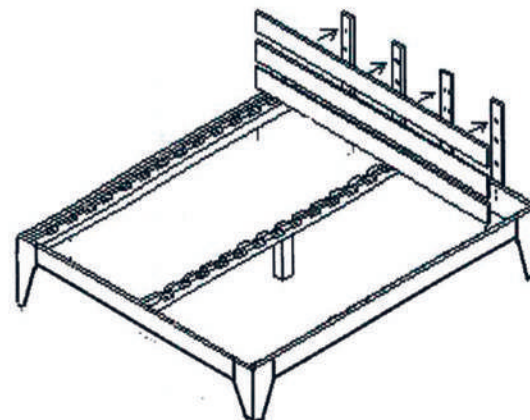

PER SINGOLO:

PER 120 - 140
160 - 180:

